

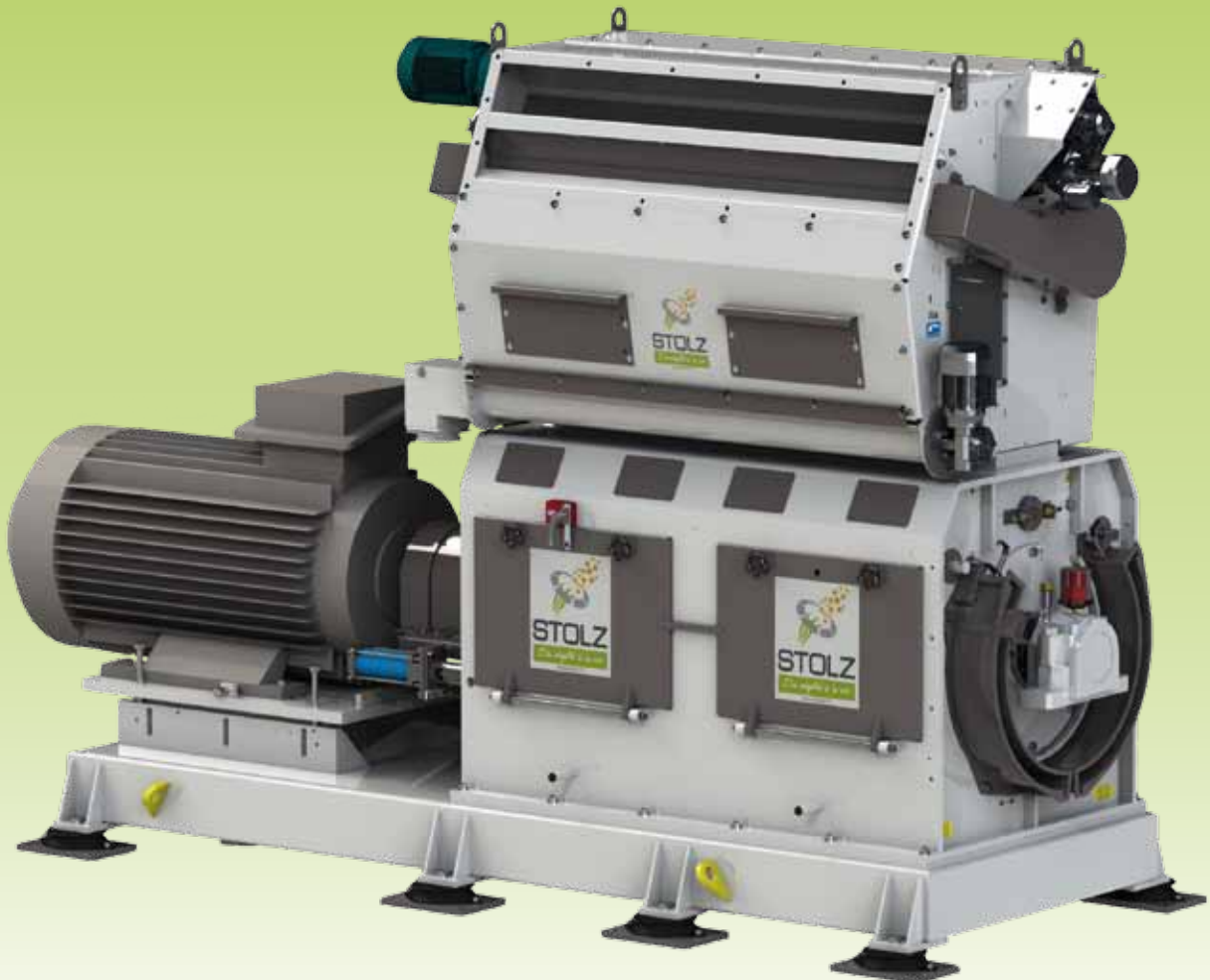

# Grinding



# Hammermill feeder ABMS



The ABMS type hammermill is the result of a long experience acquired by STOLZ company for the last few years with the concern to adapt to plants developments (production, maintenance, automation...).

Feeding the hammermill all over its length and adding cleaning functions to separate metal parts and stones have been the most important improvements.

The ABMS feeder is one block unit with a concern for aesthetic, cleanliness, automated separation of wastes, staff safety thanks to Stolz experience.



# Hammermill feeder ABMS

## Features

**Placed at machine inlet, this machine has many advantages:**

- Magnetic separator with pneumatic cylinder, automatically operated or remote controlled by an operator.
- Removal of heavy particles, especially stones and non-ferrous metals.
- Quality of hammermill feeding leading to the wear of screens and hammers to be the same all over the rotor length.
- Increase of screens and hammers lifetime thanks to a regular and homogeneous feeding.
- Assembly on the hammermill with silent-block.

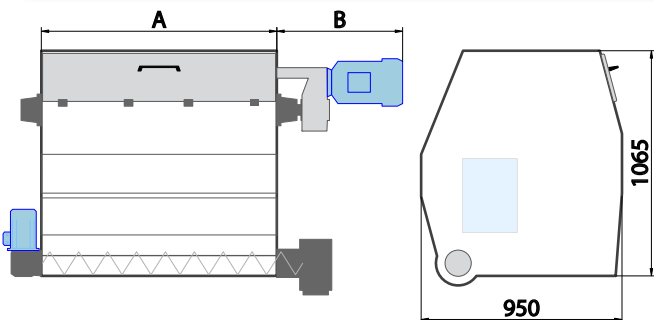
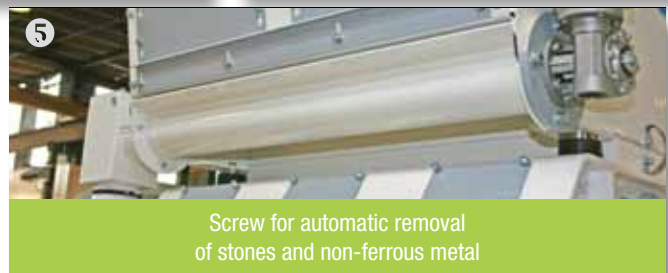
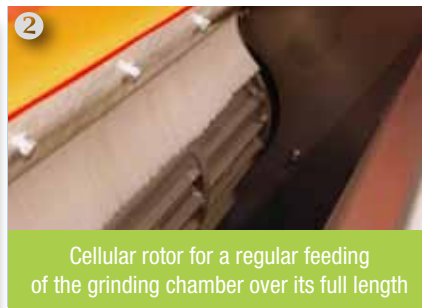
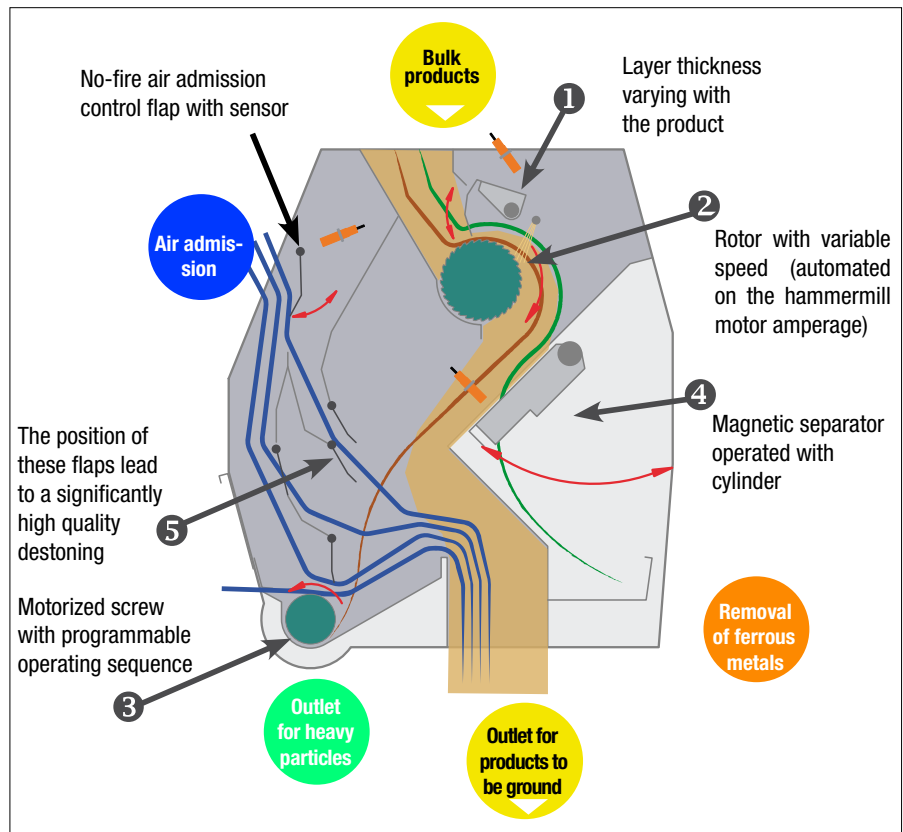

Type	Power (kW)	Mass (kg)	Dimensions (mm)	
			A	B
ABMS 4	1,5	530	574	530
ABMS 8	1,5	650	934	530
ABMS 10	1,5	720	1114	530
ABMS 14	2,2	840	1484	610
ABMS 16	2,2	900	1629	610

# Hammermills

## RM & RMP



### Features

- Two-way direction of rotation up to 3600 rpm
- Effective screening area from 0.45 to 2.20 m<sup>2</sup>
- Quick change of hammers by tilting
- Change of screens during operation
- Continuous control of bearings and grinding chamber temperatures
- Adjustable feeding flap
- Grinding chamber fitted with grooved armor plate and counter-hammers

### Range

- RM type : Manual removal of screens
- RMP type : Manual removal of screens by means of pneumatic cylinders (French patent n°93-051-88)

The equipment is also available with a grinding chamber with reinforced seal for fine grinding process.





# Hammermills RM & RMP

## Options

### Fine grinding

STOLZ has developed a new grinding / sieving concept in order to offer solutions for an even finer grinding dedicated to specific food formulas for extrusion meeting the users requirements.

Our sifters with two-way centrifugal rotation and automatic cleaning during operation are mounted at hammermills outlet with 400 to 1600 mm chamber width, and 37 to 355 kW.

Such concept, combined with the RM hammermill reputation and our high quality ABMS pneumatic feeder-metal remover-destoner appeal to several dozens of customers each year.



Splitter box for a quick connection to the supervision

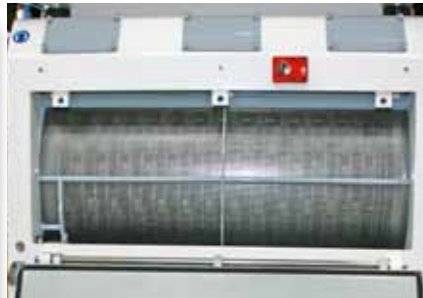

Grinding chamber fully taken up by the screens

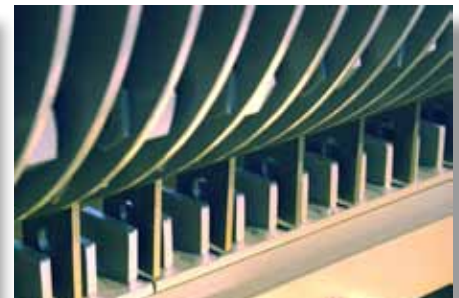

Hard steel Hammers and counter-hammers

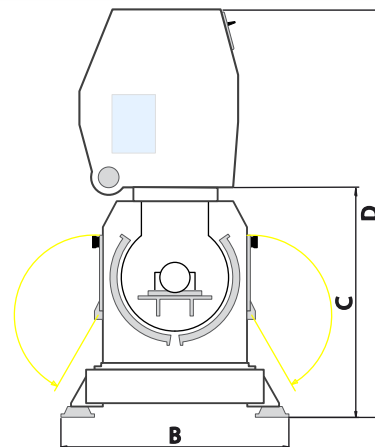
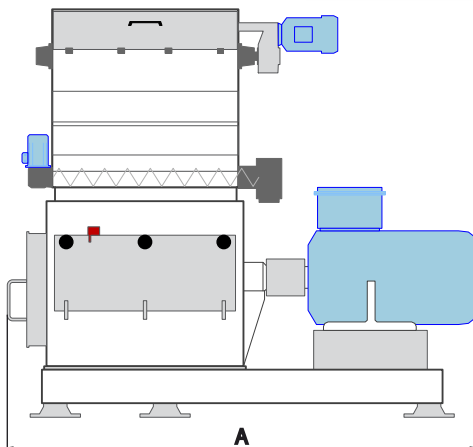

Type	Power (kW)	Hammermill mass with motor and ABMS	Quantity of hammers	Effective screening area (m <sup>2</sup> )	Dimensions (mm)			
					A*	B	C	D
RM 14	45/75	3200	52	0,70	2150	1360	1360	2430
RMP 18	90/132	4150	92	1,25	2615	1360	1360	2430
RMP 110	110/160	4550	112	1,50	2800	1360	1360	2430
RMP 114	180/250	5800	152	2,00	3595	1455	1415	2485
RMP 116	200/355	6900	168	2,20	3740	1455	1415	2485

\* 'A' dimension given for a standard motor

# Self standing automatic screen selector SAGA



The automatic SAGA screen selector is designed to insert one of the sets of screens in stand by through data exchange with the production automaton without any manual operation.

The automation at this step involves a huge reduction of production downtimes, improves the production flexibility and ensures a traceability of screens.

Working conditions are improved by the limited risks of accidents and noise exposure.



# Self standing automatic screen selector SAGA

## Features and options

### Features

- Traceability of screens
- Limited downtimes
- 2 or 4 sets of available screens
- Improved working conditions

### Options

- Electrical Box
- Set of safety signs boards
- Frames with locking flatbar cylinder
- Sets of screens

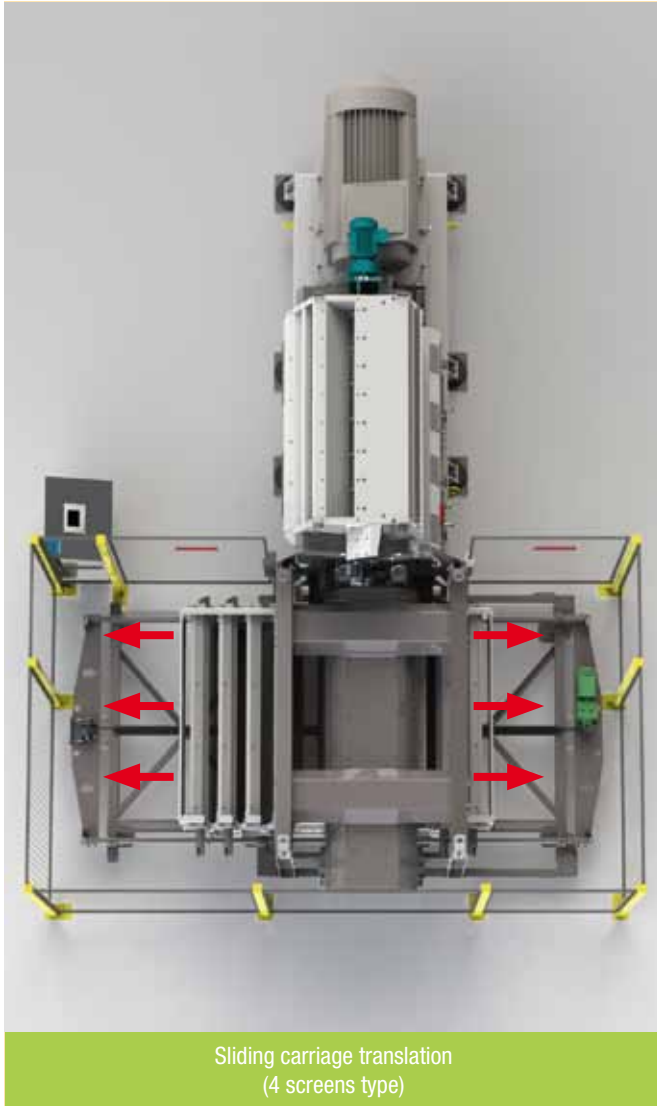

Sliding carriage translation  
(4 screens type)

### Assets

The SAGA may be adapted to STOLZ RMP type hammermills from 110 to 116 type. The use of SAGA involves a limited plant downtime.

The SAGA may be integrated in the limited space of an existing grinding unit with manual screen exchange.

The totally electrical driven movements ensure smooth movements, increased safety and power saving.



Self standing  
automatic screen selector

For hammermill type	Screens sets	Dimensions (mm)		
		Width	Length	Height
RMP 110	2 / 4	3180 / 4240	2000	2120
RMP 114	2 / 4	3180 / 4240	2340	2120
RMP 116	2 / 4	3180 / 4240	2480	2120

# Hammermills

## RMA



### Features

- Two-way direction of rotation up to 3600 rpm
- Effective screening area from 0.45 to 2.20 m<sup>2</sup>
- Quick change of hammers by tilting
- Automatic exchange of screens during operation
- Continuous control of bearings and grinding chamber temperatures
- Adjustable feeding flap
- Grinding chamber fitted with grooved armor plate and counter-hammers

Such equipment is also available with a grinding chamber with reinforced seali for fine grinding process.





# Hammermills RMA

## Automatic exchange of screens



Hammermill with automatic change of screens during operation

In the RMA configuration, the automatic exchange of screens is automatic and achieved during operation..

The screens are fitted into 2 rigid half frames sliding inside the grinding chamber guided by cylindrical rods on interdependent ball sockets of the chamber and supports with bearings.

The change is performed by 2 pneumatic cylinders.

When passing through the crushing chamber, the sealing is carried out by special brushes that can be easily dismantled.



Rotary actuator for feeding flap direction



Fast tilting of hammers



Temperature gauge on grinding chamber

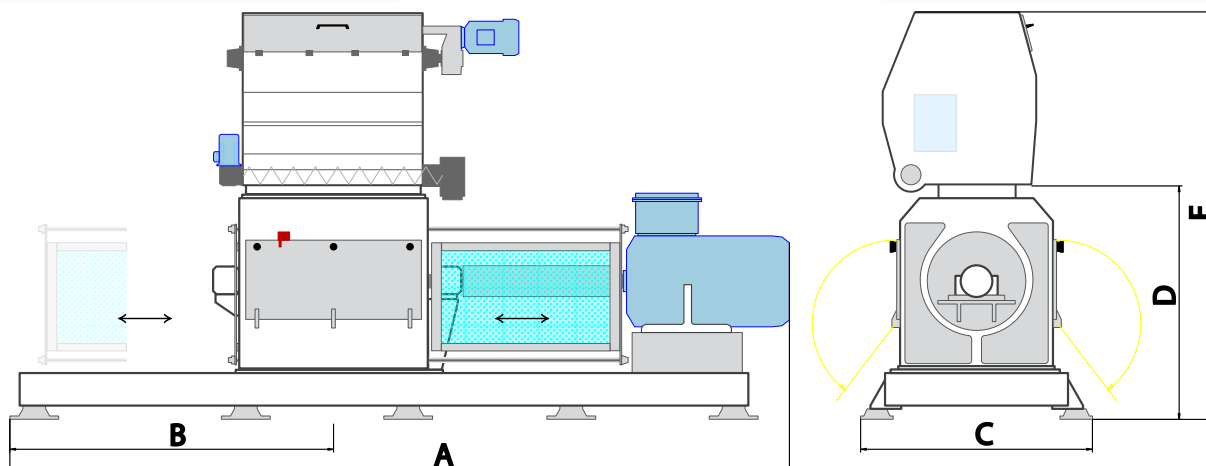

Type	Power (kW)	Hammer-mill mass with motor and ABMS	Quantity of hammers	Effective screening area (m <sup>2</sup> )	Dimensions (mm)				
					A*	B	C	D	E
RMA 18	90/132	4350	92	1,10	4410	1900	1425	1435	2505
RMA 110	110/160	5000	112	1,35	4795	1990	1425	1435	2505
RMA 114	180/200	8050	152	1,95	6270	2500	1540	1535	2605

\* 'A' dimension given for a standard motor

# Hammermills

## RME



The RME hammermill is derived from the RM range. It is adapted to meet reliability criteria required by industries requiring a very high mechanical and wearing strength to face high impact loads (knackery, paper blocks, cakes, cassava roots, etc...)

The hammermill is usually fed by a belt conveyor with adjustable speed.

The powder is conveyed by a hopper and a screw conveyor.

### Features

- Two-way rotation
- Screen exchange when machine is at a standstill
- Speed 3000 rpm
- Grinding chamber equipped with grooved armor plates
- Very thick hammers

# Hammermills RME

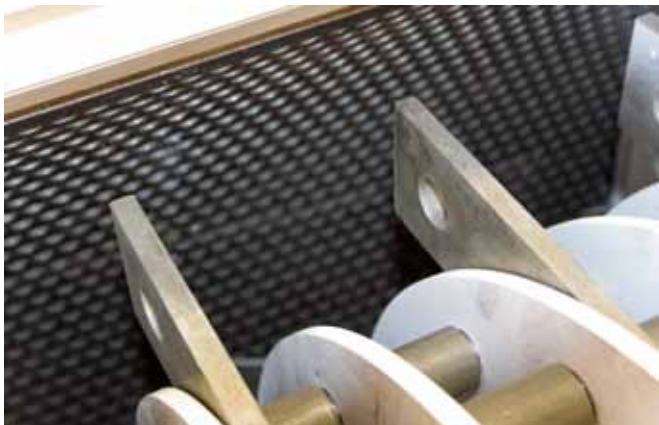

Alloy and treated steel hammers



Screens with robust frames

## Rotor



Robust rotor design

It consists of a hard steel shaft provided with braced discs supporting hammers machined in a special alloy and treated steel. These hammers are bored with two holes to work on the 4 angles, and oscillating on supporting axis made of treated hard steel.

The rotor turns on a plummer block housing roller bearings fitted outside the chamber.

Their lubrication is ensured by automatic autonomous greasing devices.

The drive is ensured by a semi-flexible coupling sleeve.

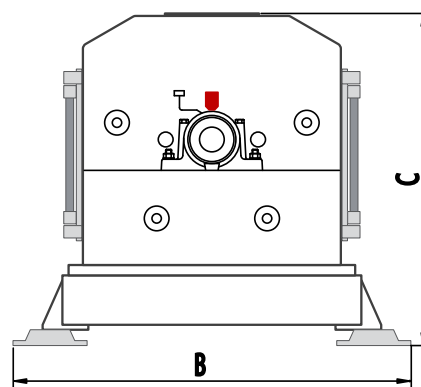
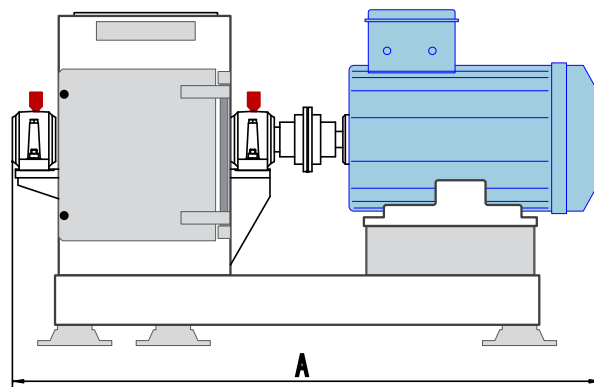

Type	Power (kW)	Hammermill mass without motor	Quantity of hammers	Effective screening area (m <sup>2</sup> )	Dimensions (mm)		
					A*	B	C
RME 14	55	3050	40	0,7	2370	1610	1345
RME 17	110	3650	56	1,1	2600	1610	1345

\* 'A' dimension given for a standard motor

# Lump breaker

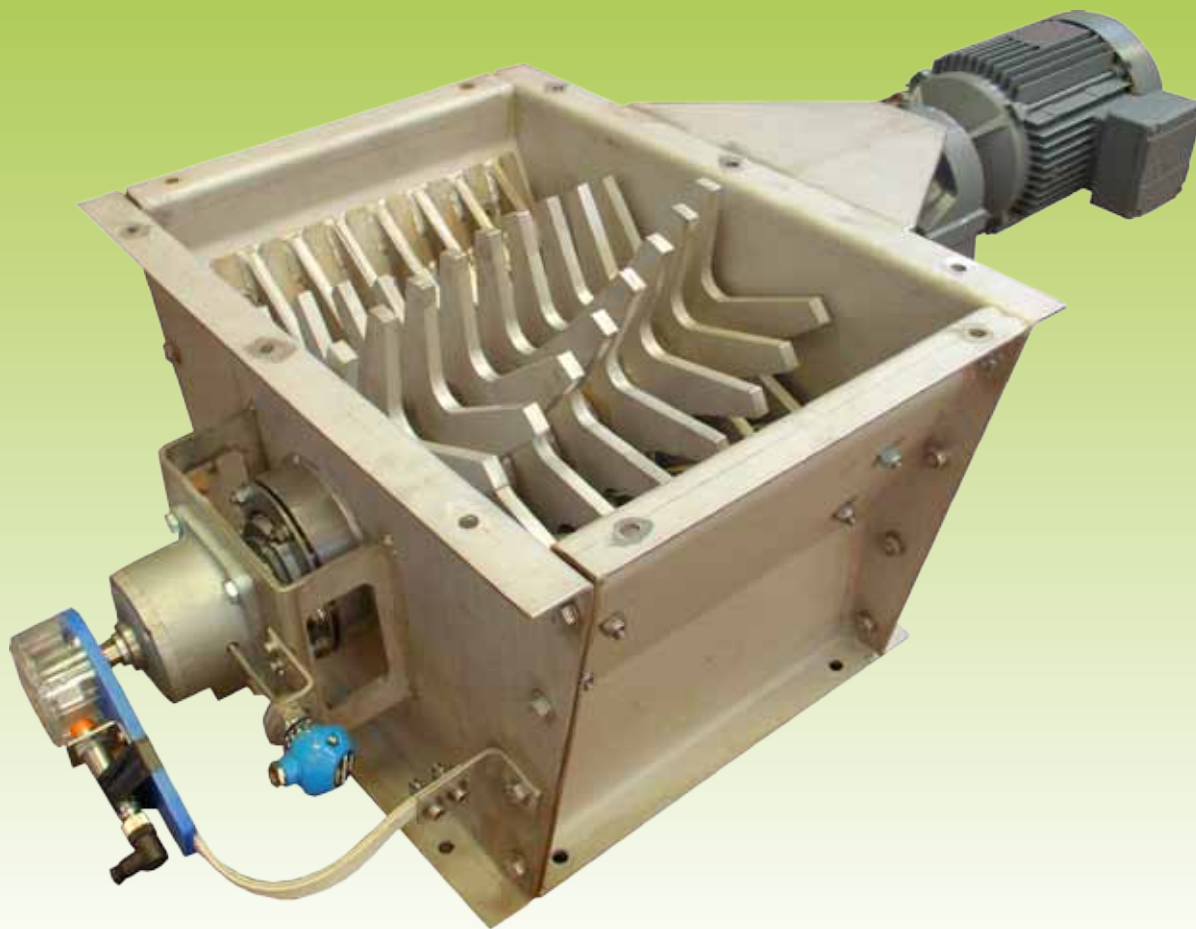

The Lump breaker can be installed at all product inlets (in bulk or in bags) when the particle size of a product required to be powered.

The crusher can be assembled in a circuit under a discharging hopper or a bag unloader but it is not designed to turn a non friable raw material into powder.



# Lump breaker

## Features and options

### Features

The lump breaker includes one or two rotors depending on the required capacity. It has two versions, coarse or fine, according to the required particle size.

### Options

- Rotation sensor
- Temperature probes on bearings

## The rotor

It consists of a steel shaft fitted with cross braced disks supporting special steel disks. These offset disks have teeth with inclined geometry forcing the product flow between each interval.

The disks are separated from one another by guides assembled on shaft.

The rotor turns on flanged bearings with self-aligning roller bearing mounted outside on supporting frame and are separated from the machine sides.

Their lubrication is ensured by manual greasing devices, and direct drive by hollow shaft gear motor.



Single rotor lump breaker



Double rotor lump breaker with toothed discs optimized for cassava

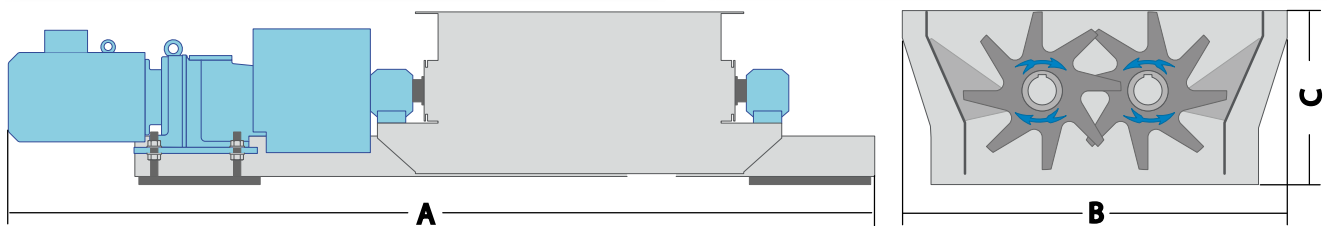

Type	Quantity of rotors	Power	Mass	Dimensions (mm)		
		(kW)	(kg)	A	B	C
BMG1	1	1x2,2	230	1210	660	400
BMF1	1	1x2,2	240	1210	660	400
BMG2	2	2x5,5	920	2150	960	430
BMF2	2	2x5,5	1035	2150	960	430

Drawing : lump breaker with double row of toothed discs

# Crumbler PEDT

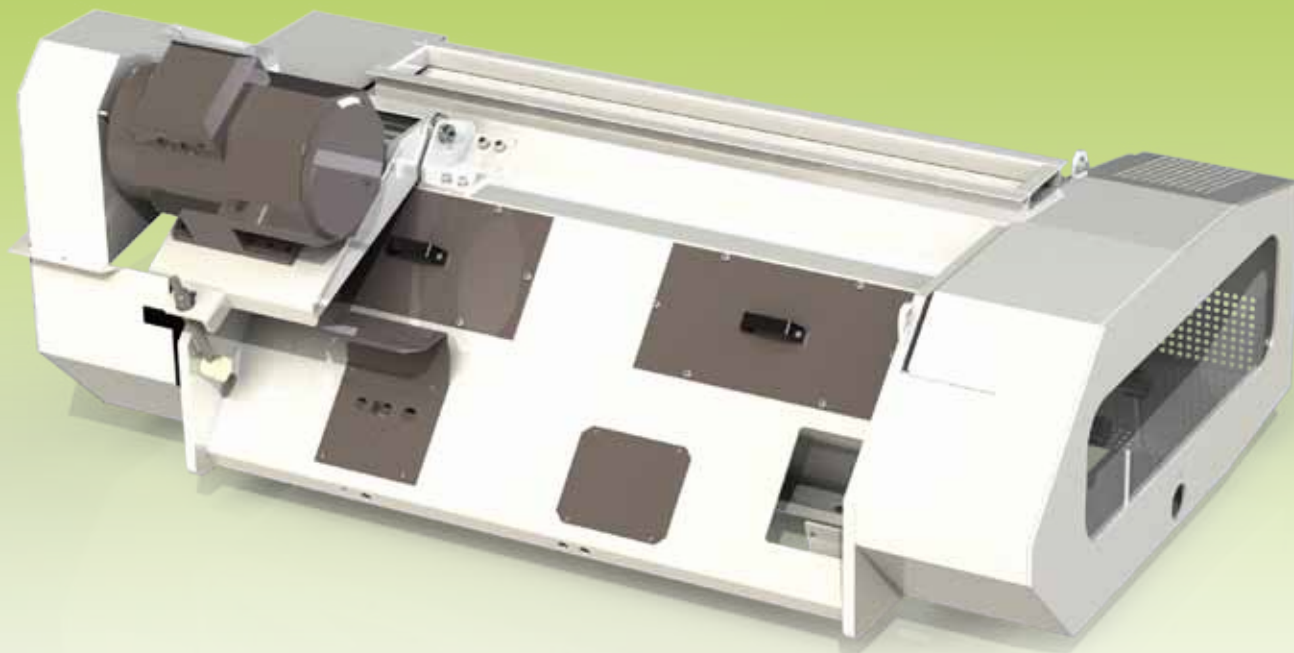

Our range of crumblers is designed to make crumbs from 0.2 to 4 mm with granulated product passing between 2 rollers.

The main feature of STOLZ PEDT crumbler is the possible use of the distributor permanently in order to regulate the pellet flow before sifting.

## Features:

- Ø250 mm rollers
- Space adjustment between cylinders with remote control
- Integrated system for product sampling
- Automatic spacing of cylinders when foreign bodies crossing
- Total spacing of rollers to provide a free passage of pellets



# Crumbler PEDT

## Features

### The purpose of Stolz crumbler:

To crush pellets (usually a 4 mm diameter is easier to pellet than a 2.5 mm diameter) for poultry, game, fish, and piglets thus improving ingestion by small animals and digestion.

Our PEDT crumbler is also used to reduce the grain size of various dry products use in food or chemical industries.

Cylinder surface area geometry is adjusted to the products to be treated according to their nature and original size.



Crumbler  
beneath cooler



Control cabinet for spacing  
between rollers



Rollers  
driven by notched belts

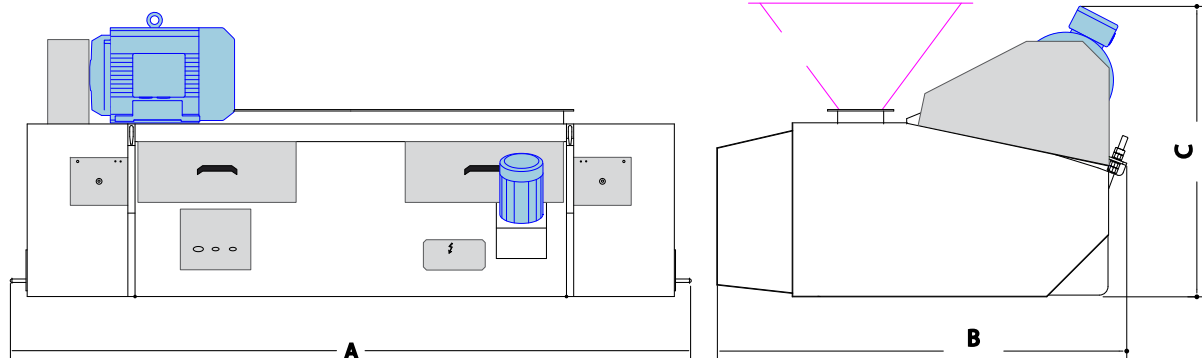

Type	Capacity	Power	Mass	Dimensions (mm)		
	t/h	(kW)	(kg)	A	B	C
PEDT 600	4 à 6	7,5	1100	1590	1460	1010
PEDT 1000	8 à 12	11	1400	1990	1460	1010
PEDT 1500	12 à 18	15	1850	2490	1460	1010
PEDT 1800	15 à 25	18,5	2200	2790	1460	1010



# Grinding line

## Hopper and screw discharge



The RMP or RMA type hammermills are generally installed on a concrete or metal floor and fixed with anti-vibrating mountings.

The air enters the ABMS feeder and crosses the screens and then the automatic cleaning filter.

The air is forced out after passing through a muffler.

The motorized flap controls the air flow-rate at the centrifugal fan inlet.

The ground product is discharged by the screw conveyor equipped with a sealing flap or even a rotatory valve.



# Grinding line with hopper and screw discharge

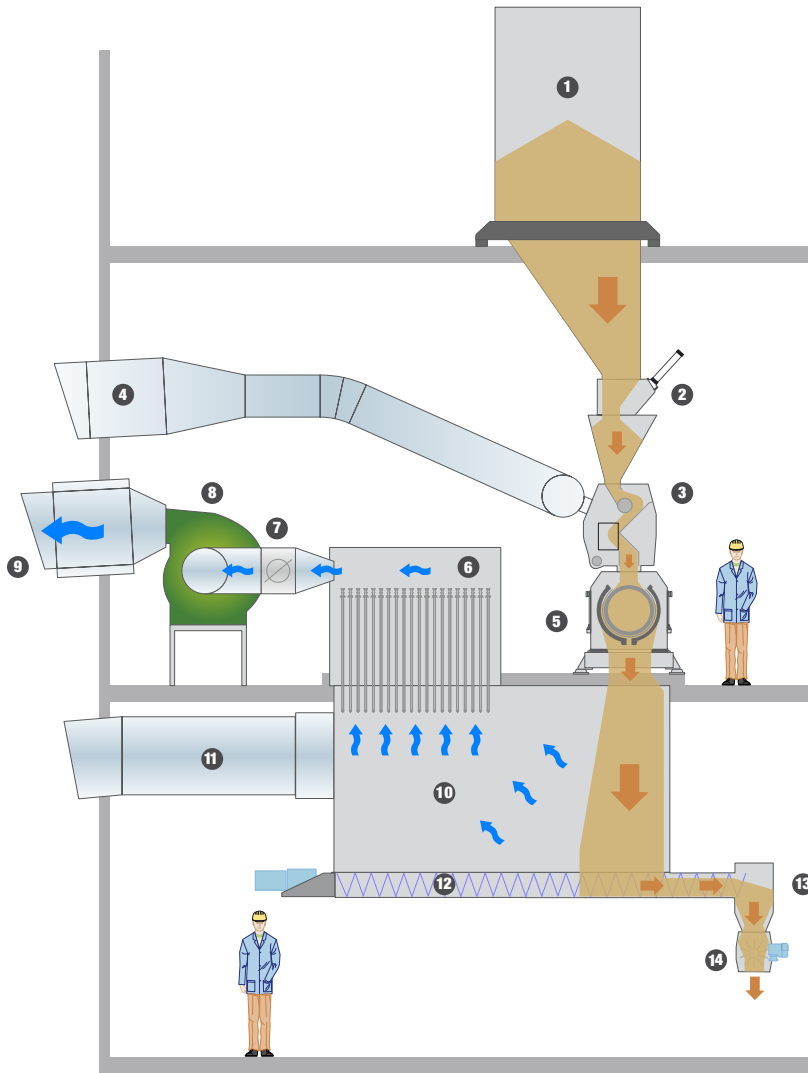

## Caption

- ① Hopper
- ② Helmet gate
- ③ ABMS feeder (destoner, ferrous cleaner)
- ④ Air intake (Atex option)
- ⑤ Hammermill
- ⑥ Filter
- ⑦ Motorized flap
- ⑧ Centrifugal fan
- ⑨ Silencer (option)
- ⑩ Hopper under hammermill
- ⑪ Explosion vent and air outlet duct (Atex option)
- ⑫ Screw conveyor
- ⑬ Sealing valve
- ⑭ Rotary valve



Hopper beneath hammermill



Explosion vent and outlet duct

# Grinding Line Pneumatic Conveying



The air gets in through the ABMS feeder and an additional air inlet. It passes through the screens of the hammermill. The ground product is conveyed by vacuum thanks to the fan.

An automatic cleaning filter separates the product from the air.

The air flap adjusts the air flow rate at the fan inlet. The air is forced out after going through a muffler.

Considering the fineness of the product, the cyclo-filter is flat-bottomed, equipped with a motorized cleaning arm and a sealing valve.

A turbo sifter is designed to separate the products. The particles not meeting the required size are handled back towards the mill.

In ATEX area, an explosion vent and an air outlet duct provide a safe of the installation.



# Grinding line with pneumatic conveying

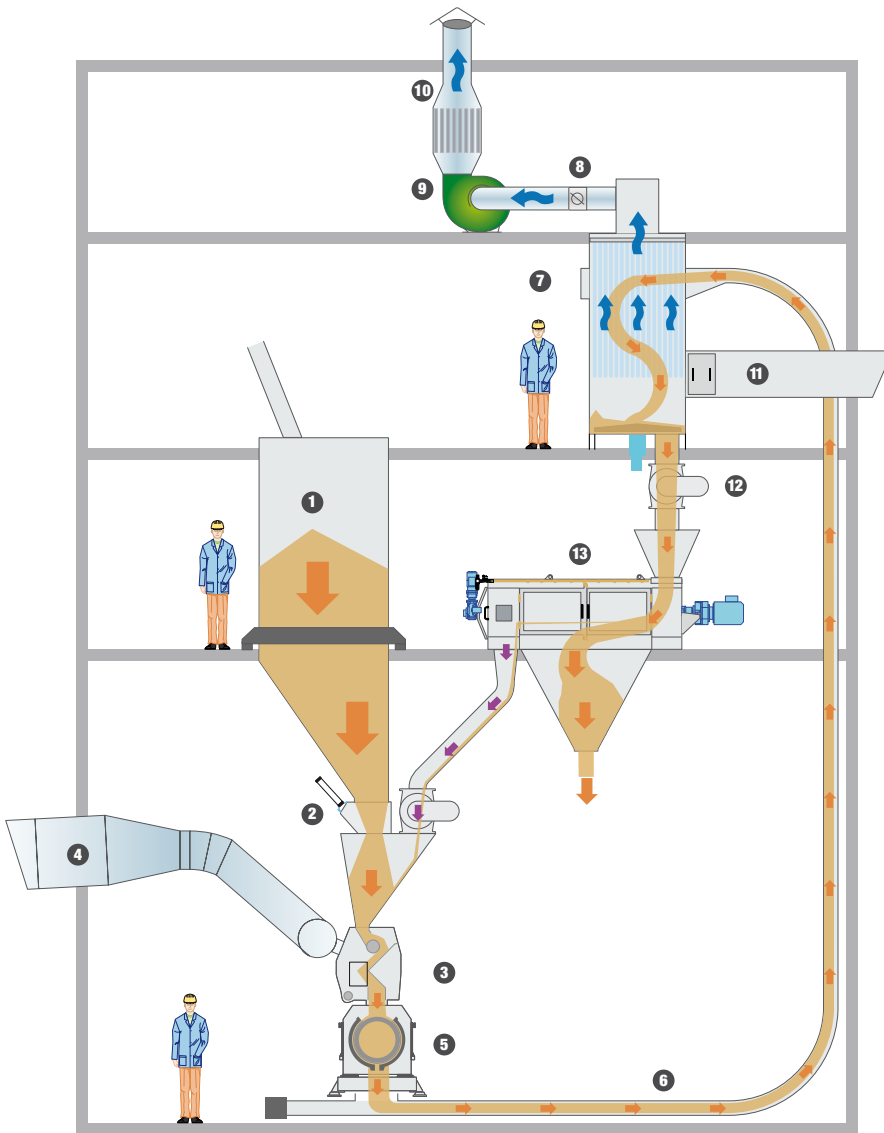

## Key

- ❶ Hopper
- ❷ Helmet gate
- ❸ ABMS feeder (destoner, ferrous cleaner)
- ❹ Air intake (Atex option)
- ❺ Hammermill
- ❻ Pneumatic transfer
- ❼ Filter with cleaning arm
- ❽ Motorized air flap
- ❾ Centrifugal fan
- ❿ Nuffler (option)
- ⓫ Explosion vent and air outlet duct (Atex option)
- ⓬ Sealing valve
- ⓭ Turbosifter



Cyclo-filter and fan



Filter with cleaning arm



Pneumatic conveying



# STOLZ

*Du végétal à la vie*

[www.stolz.fr](http://www.stolz.fr)



STOLZ SEQUIPAG SA  
82 route de Boisjean - 62170 WAILLY-BEAUCAMP - FRANCE  
Tel: + 33 (0)3 21 81 90 05 05 - Fax: + 33 (0)3 21 90 05 15  
E-mail : [contact@stolz.fr](mailto:contact@stolz.fr)